

# **H O M E O W N E R ' S   M A N U A L**

---

## **Community Wastewater Collection & Treatment System**



### *Jacks Point*

*Important Facts on the Installation and Care  
For Homes with Community Wastewater  
Collection and Treatment Systems*



***INNOFLOW TECHNOLOGIES***  
**INNOVATIVE WASTEWATER MANAGEMENT**

# HOMEOWNER'S MANUAL

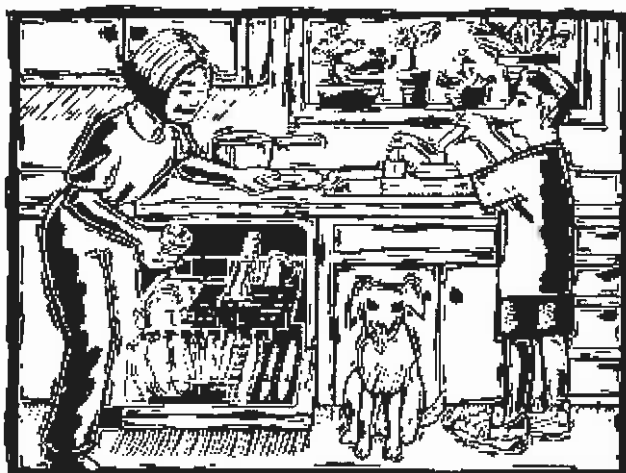

## *Congratulations!*

Protecting the special character and environment at *Jacks Point* has been of paramount importance in the development of this community. That's why a high performance, state-of-the-art wastewater system has been used to deal with the sewage from the entire community.

Your home includes reliable, carefully engineered equipment - supplied by Innoflow Technologies - for the collection and pretreatment of household wastewater.

When properly designed and installed, an onsite wastewater treatment does a great job of decomposing household waste and recycling precious water resources. Our systems frequently outperform municipal sewage treatment plants. And the treated effluent is often returned harmlessly to the soil, where it receives final polishing and filtration for groundwater recharge. There's no degrading of our nation's rivers and oceans . . . which is so often the case with municipal sewage.

As with any engineered system, such as your car, your onsite wastewater system will work better and last longer if a qualified installer fits your system and a qualified service provider regularly maintains it.

Your service provider should be present during installation, so he or she is familiar with your system, especially those service lines, conduits, and connections that get buried. It is important that the system is installed and operated correctly and this manual outlines correct procedures for your installer or future service provider.

Your system will also work better and last longer if you learn what can go into it — and what cannot. Little effort is required. Just read and practice the "do's and don'ts" that follow. Every member of your household should be familiar with these. And if you have guests who want to "help out in the kitchen," be sure to tell them, too. With this preventive maintenance, along with periodic inspections, your onsite wastewater system should function for decades. And you'll save water and energy, too!

There's a place on the back of this Homeowner's Manual to record "Important System Facts." If those have not been filled in for you, please record those now, before you file this Manual away. And give a copy of these facts to your service provider, especially if your service provider changes.

# H O M E O W N E R ' S M A N U A L



## TABLE OF CONTENTS

ABOUT THIS MANUAL .....	4
ABOUT THE COMMUNITY WASTEWATER SYSTEM .....	4
WHAT YOU NEED ON YOUR SITE AND WHY .....	5
Interceptor Tank .....	5
Remote Monitor/Manage Control Panel .....	7
ORDERING THE EQUIPMENT FOR YOUR SITE.....	9
PRICING OPTIONS .....	ERROR! BOOKMARK NOT DEFINED.
INSTALLATION OF THE ONSITE EQUIPMENT.....	11
SERVICING OF YOUR ONSITE SYSTEM .....	11
CARE OF YOUR SYSTEM.....	12
IMPORTANT ONSITE SYSTEM FACTS AND CONTACTS.....	17
FREQUENTLY ASKED QUESTIONS .....	18
INSTRUCTIONS FOR INSTALLERS.....	19
PROSTEP™ INTERCEPTOR TANK INSTALLATION AND CONNECTION .....	19
Guidelines for Siting the Tank .....	19
House to Interceptor tank Connection.....	20
Service Lateral.....	21
Service Connection .....	22
PROSTEP™ ON-LOT INTERCEPTOR TANK ORDER FORM .....	23
PROSTEP™ ON-LOT INTERCEPTOR TANK CHECKLIST .....	24
PROSTEP™ ON-LOT INTERCEPTOR TANK SPECIFICATION DATA SHEET .....	25

# H O M E O W N E R ' S M A N U A L



## ABOUT THIS MANUAL

Part of the community sewage system at *Jacks Point* is a modern wastewater pre-treatment and collection system on each lot. It is important to the operation of the community system that you, as part of the community and purchaser of the on-lot equipment, understand the process. This will enable you to ensure that the correct equipment is purchased, it is installed in the approved manner, and it is maintained and treated with appropriate care.

This manual outlines the on-lot equipment required for the collection system, how it works and how to take care of it. Information for installers and service providers is also provided to ensure correct long-term operation.

There is an order form for the interceptor tanks and an installation checklist form that should be completed and returned to InnoFlow Technologies when you are ready to order the interceptor tank.

Information on interceptor tank costings and connection fees are included at the end of this document.

## ABOUT THE COMMUNITY WASTEWATER SYSTEM

The wastewater scheme at *Jacks Point* provides the homeowner with a "flush and forget" service and requires no significant homeowner involvement.

The design and layout of the scheme revolves around a *ProSTEP™* effluent sewer reticulated network. This pipe network has been installed at *Jacks Point* to transport effluent from each lot to the community treatment plant (see Fig. 1). This watertight collection system offers many advantages over traditional sewers and is now considered best practice for community systems. The treatment plant is based on the well-proven AdvanTex® treatment technology. This is a reliable and robust treatment process that consistently treats the wastewater to an advanced level. It produces a clear, odourless liquid, useful for drip irrigation applications.

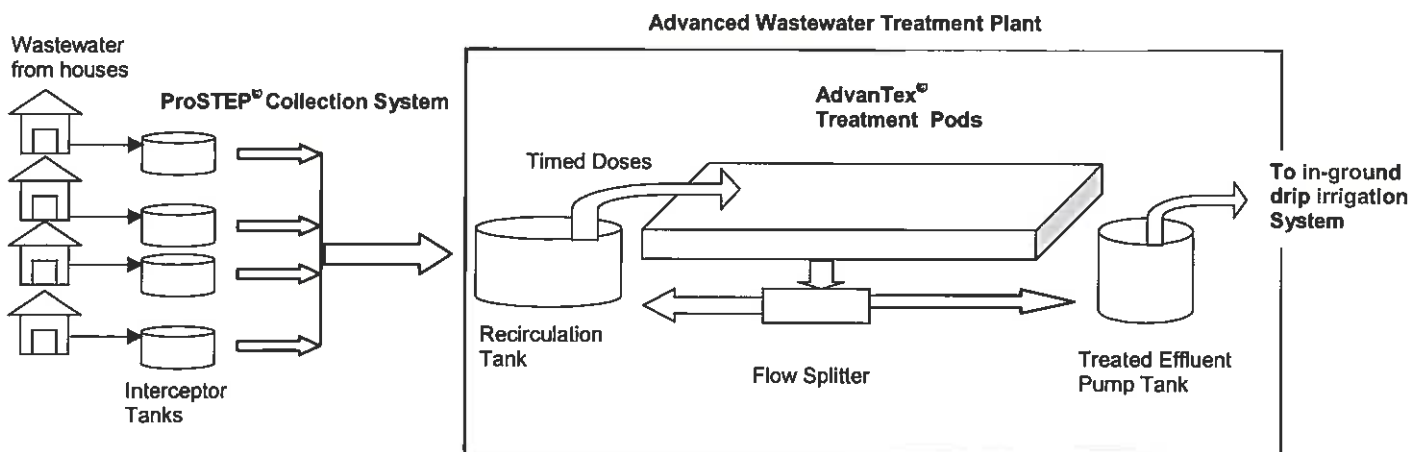

Figure 1. Wastewater Management System Flow Train

# HOMEOWNER'S MANUAL



## WHAT YOU NEED ON YOUR SITE AND WHY

The effluent sewer is dependant on a number of factors to ensure high performance and low maintenance.

To ensure that the effluent sewer network works properly, a specifically sized and constructed tank must be installed on each property to service the wastewater from the dwelling. This tank is called an on-lot interceptor tank and must also contain a specifically designed effluent filter, pump and discharge assembly and a specific control panel monitored by telemetry.

The following pages detail some information that will not only give you a better understanding of the on-lot part of the wastewater management process at Jacks Point, but also provides some information to ensure the successful installation, and optimum operation of your on-lot interceptor tank.

The components that make up the on-lot component of the scheme at Jacks Point are described below and include:

- Conventional **gravity sewer** from the dwelling to the interceptor tank inlet
- Buried concrete **interceptor tank** and equipment
- Small diameter **service lateral** from tank to boundary service connection
- A **service connection** which connects the on-lot components to the *ProSTEP™* effluent sewer

The key feature of the on-lot stage of the *ProSTEP™* effluent sewer process is the interceptor tank. Its design has been optimised to ensure effective primary treatment and solids retention with minimal maintenance.

### Interceptor Tank

Some of the features of the on-lot interceptor tank are:

#### Size

The tank is specifically designed based on the number of bedrooms in the dwelling serviced by the system and on the optimum desludging period. For these reasons the interceptor tanks that must be installed on each property are generally of a larger size then normally manufactured. It is therefore not appropriate to purchase any tank other than the one specified.

The standard interceptor tank for each lot at *Jacks Point* has a working volume of 4500 litres; this tank is suitable for up to 4 bedrooms. Please note that InnoFlow Technologies generally adopts ARC TP58 as the standard for waste water calculations and on that basis any of the following must be taken into account as bedrooms for the sizing of the interceptor tank

- Rumpus Rooms
- Games Rooms
- Studies
- Libraries
- Granny Flats
- Sleep outs

If you plan to build a house that is larger than 4 bedrooms, including any of the above, please contact InnoFlow Technologies, as special consideration will have to be made for the design and sizing of your interceptor tank.

The standard interceptor tank is oval in shape. It is 3.4 metres long, 1.4 metres wide and 2.45 metres tall with access risers

#### Watertightness

One of the main reasons why the *ProSTEP™* effluent sewer is a small diameter pipe is because we are able to eliminate stormwater or groundwater infiltration from occurring. The tanks are made under strict quality control and using specifically designed equipment to ensure no water gets into the tank.

By eliminating unwanted water into the system we not only use small diameter pipes but we save on power as less pumping is required, we save on community treatment plant size because we are treating a lower flow, and we save on land area for irrigation.



# HOMEOWNER'S MANUAL



To ensure that the entire system remains free of unwanted stormwater or groundwater infiltration we recommend the tank is installed to ensure no water can get into the tanks either through the tank lids or air vents and that no stormwater downpipes are connected into the gully traps of the dwelling.

## *Biotube® Pumping System*

The pumping system installed inside each tank at Jacks Point is a fully integrated equipment package designed specifically for primary wastewater treatment.

## *Tank Siting*

While the specific location of the septic tank on your property is flexible, there are a few considerations that should be made when siting your interceptor tank.

- Access for septic tank clean-out truck
- Access for service technicians
- Fall from standard sewer
- Distance to service connection (standard includes up to 25 metres)
- Location of control panel
- Away from vehicular traffic (foot traffic is ok)

The Plumbing and Drainage Act, 1978 requires the interceptor tank to be installed a minimum of 3 metres off a building and 1.5 metres off a property boundary. For further information on setback distances you should contact your local council. Jacks Point management must also provide approval as to the location of the tank and no installation can occur until their approval is provided.

More information on tank siting and installation is provided in the section on "Instructions for Installers"

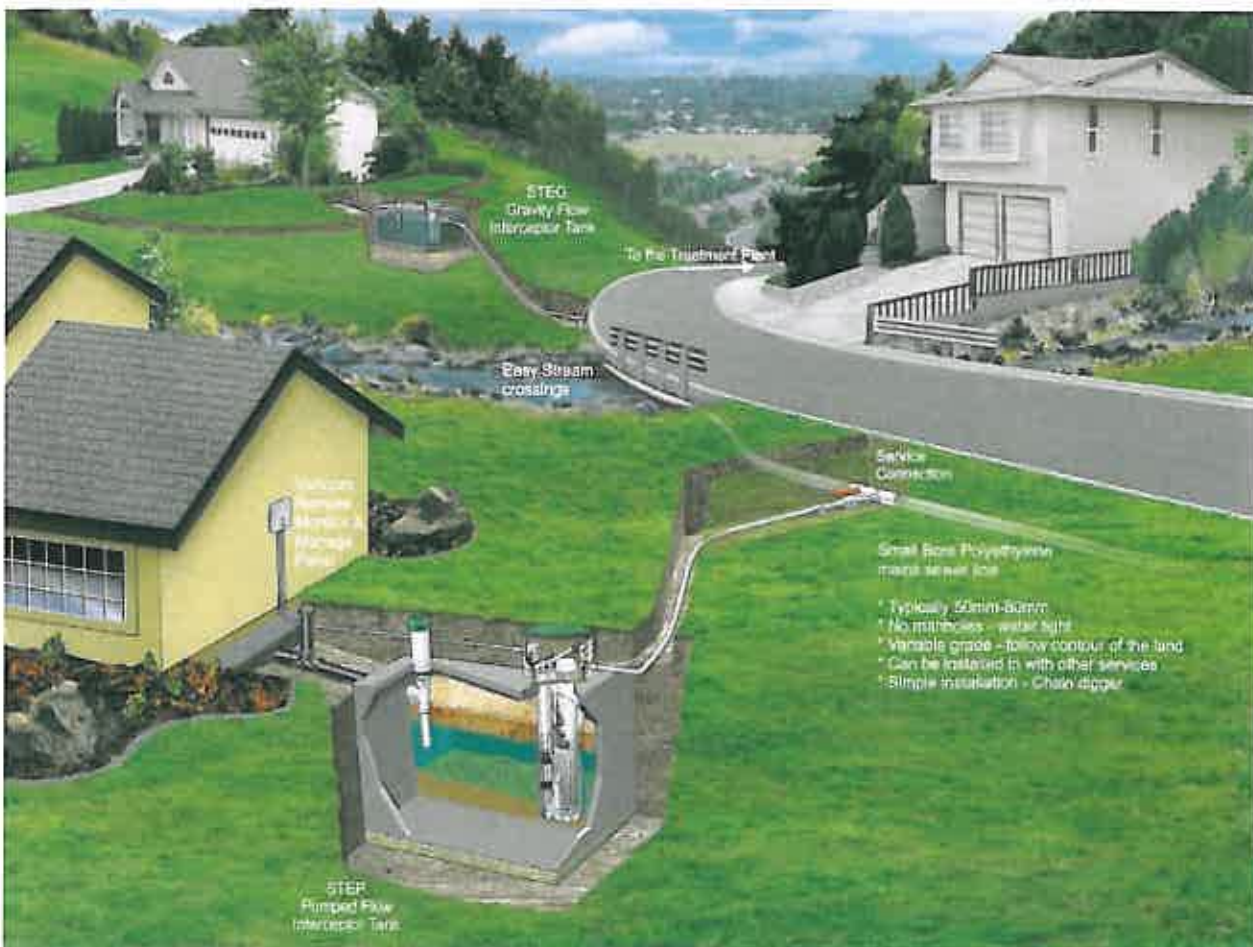

Figure 2. Schematic of a ProSTEP™ Effluent Sewer community system

# H O M E O W N E R ' S   M A N U A L



## Remote Monitor/Manage Control Panel

The control panel supplied with each interceptor tank at Jacks Point further reinforces the concept of “flush and forget” for the homeowner through the use of the VeriComm™ monitoring system.

VeriComm Control Panels give homeowners the peace of mind that comes from knowing their wastewater system is always being monitored. Through the use of a standard phone line connected to the panel, any problems or unusual conditions are alerted offsite to the Service Company, rather than “locally” at the control panel.

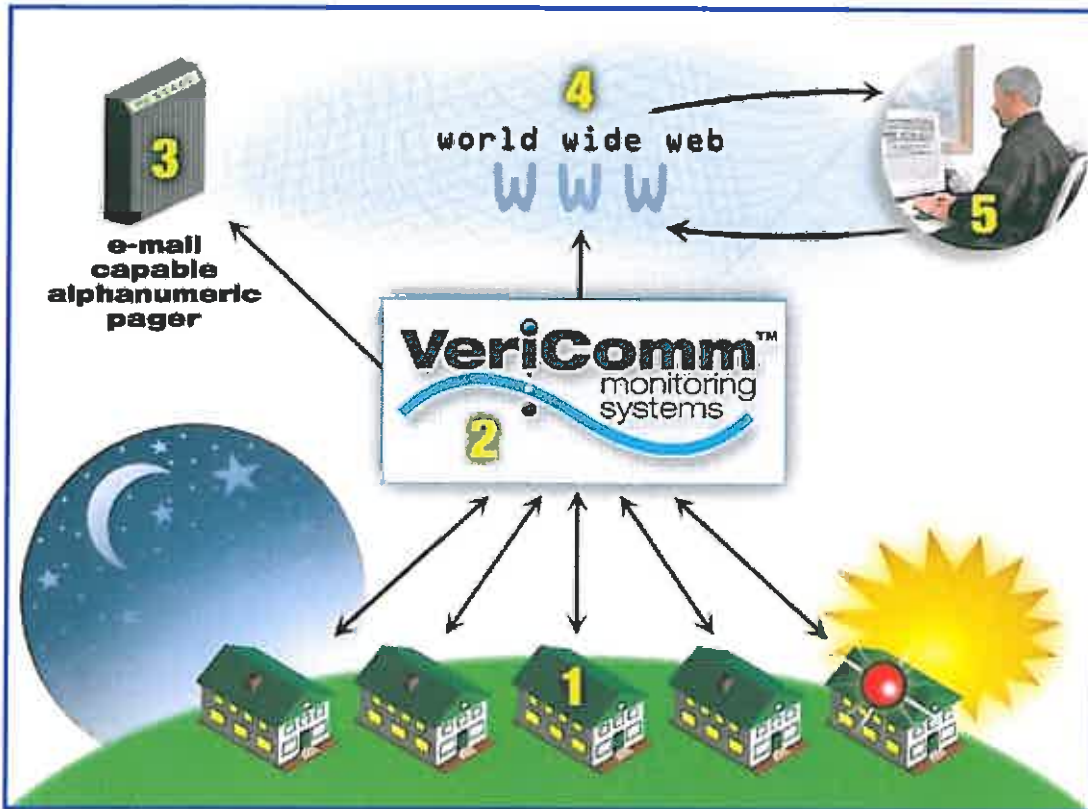

Figure 3

In addition to remote alerts and alarms, each VeriComm™ Panel constantly measures and monitors conditions on each lot in the development to ensure optimal operation of the system at all times. For example, if a float malfunctions, the service company is alerted of the problem but the panel continues to run, based on previous trend data. If water usage increases greatly compared to previous trends, the service company is notified of this anomaly.

### *How it Works*

Your control panel will “call in” once a month at a convenient time, unless there’s a problem with your system. If there’s a problem, it will call in immediately and report the problem, so your Service Provider can take care of it. (Yes, this is one very smart control panel.)

The routine, monthly phone calls take less than one minute and are made in the middle of the night, when it’s not likely you’ll need to use your phone. Alarm calls also take less than one minute, but they can occur at any time. If you’re using your phone when the panel tries to call in, you’ll hear a “click” sound. The panel will keep trying until it makes a connection.

All these phone calls are made to a toll-free number, so they will not appear on your phone bill. An active telephone line must be maintained on the property at all times.

Because your control panel uses your phone line, **DO NOT DISCONNECT THE PHONE LINES THAT GO TO YOUR CONTROL PANEL AND DO NOT DISCONNECT YOUR PHONE SERVICE.** Also, notify your service

# HOMEOWNER'S MANUAL



provider if you modify your current phone service (add voice messaging, for example), as this may adversely affect your control panel's operation.

## *Audible Alarm*

If your phone lines go down in an emergency (severe weather, other unexpected circumstances) and your panel needs to make an alarm call, it will keep trying until, at some point, it will sound a "local alarm." That means, the light on the front of the panel will start flashing and you'll hear an audible alarm sound. **IF YOU HEAR AN AUDIBLE ALARM, CALL YOUR SERVICE PROVIDER IMMEDIATELY.** Then stop the alarm sound by pressing the light button on the front of the panel.

## *Panel Installation*

The electrical installation requirements for the control panel are outlined in the document "VeriComm Control Panel VCOM-S2 RO (NZ) Manual# EIN-CP-S-657" enclosed separately. All connections to the panel are the responsibility of the homeowner, however InnoFlow Technologies can offer advice if required.

This document should be passed onto the electrician who is wiring up the on-lot interceptor tank; it outlines all requirements for the electrical and telephone hook-up for the system. Watertight electrical connections are very important and improper wiring can lead to poor system performance.

**PLEASE ENSURE YOUR SERVICE PROVIDER IS INFORMED THAT THE CONTROL PANEL HAS BEEN INSTALLED BEFORE YOUR PHONE LINE IS CONNECTED TO THE CONTROL PANEL.**



# **H O M E O W N E R ' S M A N U A L**



## **ORDERING THE EQUIPMENT FOR YOUR SITE**

Please use the following order form to order the ProSTEP™ equipment and tank required for your site. This form can be faxed to InnoFlow Technologies Ltd.

**Please do NOT use substitute equipment or tanks.** This is non-complying, can compromise the integrity of the effluent collection sewer, lead to damage at the treatment plant and void equipment warranties

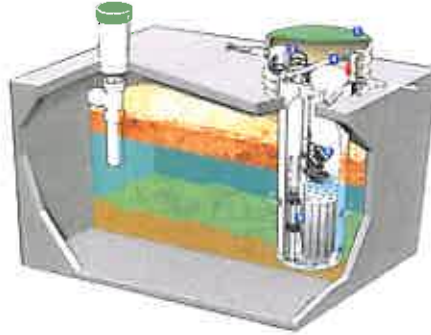

### **Supply and installation by**

4500 litre Concrete Tank  
ProSTEP Biotube® pumping system  
Watertight Access Risers and lids  
Triple Float control assembly  
VeriComm™ Remote Monitor Manage Control Panel  
Service Lateral (up to 50m, additional length @ \$10/m)  
Delivery to site  
Installation of Tank and service lateral to service connection (up to 25m, see above)

### **Approved Installer**

**Please contact Lane Vermaas, Jacks Point to arrange and organise your installation. Phone( 03)4510555**

# HOMEOWNER'S MANUAL



Please note; prices are determined by Jacks Point based on a comprehensive tender process and are not open to negotiation.

In the pricing options above, allowances for the following have not been made:

- Goods and Services Tax
- Permits and Consents
- Dewatering, Ground and storm water control (if required)
- Modified Access or Spoils removal (if required)
- Connection from Dwelling to Interceptor tank
- Electrical Hook up and mains power supply to control panel
- Telephone line supply and hook up for control panel.
- Water to fill tank

The electrician completing the house wiring will be required to provide mains power and the phone line to the control panel.

Please note: the interceptor tank creates an environment which is not ideal for use with an RCD device. **We ask that the wiring at the switch board for the interceptor tank does not involve an RCD device.**

Alternatively, we will forward an electrical wiring manual for the electrician to use when connecting the electrical components.

Upon completion of the installation (including all wiring, drainage connections and telephone connection, and filling of the tank with water), **it is important that InnoFlow Technologies NZ Ltd are contacted so we can commission the tank and undertake a diagnostic test of the panel and phone line.** Use of the tank prior to this commissioning may result in a cancellation of warranty on equipment. Note: this service is offered free of charge if an approved installer has installed the tank.

Please note that we have tanks on order for the Jacks Point project, however, their availability is dependant on the manufacturer's current commitments and existing orders by other lot owners.

# **H O M E O W N E R ' S M A N U A L**



## **INSTALLATION OF THE ONSITE EQUIPMENT**

An appropriate installer will be required to install the ProSTEP™ interceptor tank and equipment and connect it to your house and the sewer line. An electrician is needed to wire up the pumps, float switches and control panel. Installation instructions are included with this document and should be given to the installer and electrician.

Once you have arranged for the tank and equipment to be installed, pumps wired to control panel, and power supply wired to control panel, you should contact InnoFlow Technologies to commission the system, before you start using it.

A checklist has been provided in the back of this manual, which can be used ensure all the steps involved in the ordering, installation, commissioning and testing of your on-lot Interceptor tank have been completed.

The checklist has been broken into two sections. The first section is for you; the homeowner to fill out to ensure everything is ready on the day for the installer and electrician to complete the work in a timely and professional manner.

The second section is for the installer and electrician to complete following installation to check that all the tasks have been carried out such that the control panel is ready for InnoFlow Technologies to perform the final checks and ultimately the tank ready for you to use.

## **SERVICING OF YOUR ONSITE SYSTEM**

The ProSTEP™ equipment is designed to have minimal servicing requirements, and the maintenance procedures and periodic inspections are designed to ensure the long life and correct operation of the system. Typically this requires an annual service call.

Only an authorised service provider should service your on-site equipment. Contact your supplier or InnoFlow Technologies Ltd for the approved service provider in your area.

# HOMEOWNER'S MANUAL



## CARE OF YOUR SYSTEM

Your system will work better and provide trouble-free performance if you learn what can go in to it and what cannot. Just read and practice the "do's and don'ts" that follow. Every member of the household should be familiar with these.

### DO'S AND DON'TS FOR INSIDE THE HOUSE



**DON'T** flush dangerous and damaging substances into your wastewater treatment system. (Please refer to the "Substitutes for Household Hazardous Waste.") Specifically, do not flush . . .

- Excessive amounts of bath or body oils
- Water softener backwash
- Flammable or toxic products
- Household cleaners, especially floor wax and rug cleaners
- Chlorine bleach, chlorides, and pool or spa products
- Pesticides, herbicides, or agricultural chemicals or fertilizers



**DO** use your trash can to dispose of substances that cause maintenance problems and/or increase the need for septage pumping. Dispose of the following with your trash:

- Egg shells, cantaloupe seeds, gum, coffee grounds, tea bags, chewing tobacco, cigarette butts
- Paper towels, newspapers, sanitary napkins, diapers, kitty litter, candy wrappers
- Cooking grease
- Rags, large amounts of hair

*disposed into any wastewater system that hasn't first been ingested, other than toilet tissue, mild detergents, and wash water. Here are some additional guidelines.*

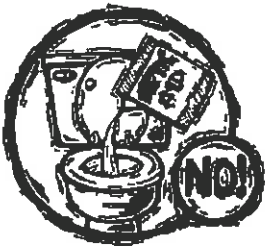

**DON'T** use special additives that are touted to enhance the performance of your tank or system. Additives can cause major damage to your drainfield and other areas in the collection system. The natural microorganisms that grow in your system generate their own enzymes that are sufficient for breaking down and digesting nutrients in the wastewater.

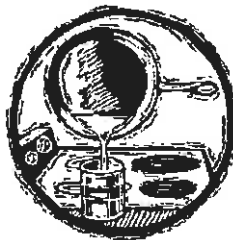

**DO** collect grease in a container and dispose with your trash. And avoid using garbage disposals excessively. Compost scraps or dispose with your trash, also. Food byproducts accelerate the need for septage pumping and increase maintenance.

*There are a number of do's and don'ts that will help ensure a long life and minimal maintenance for your system. As a general rule, nothing should be*

# HOMEOWNER'S MANUAL



## DO'S AND DON'TS FOR INSIDE THE HOUSE



**DON'T** leave interior faucets on to protect water lines during cold spells. A running faucet can easily increase your wastewater flow by 1,000 to 3,000 gallons per day and hydraulically overload your system. Instead, properly insulate or heat your faucets and plumbing.

**DON'T** use excessive amounts of water. Using 50 gallons per person per day is typical. If your household does not practice any of the "water conserving tips" below, you may be using too much water.

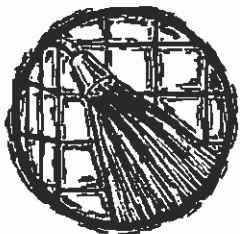

**DO** conserve water:

- Take shorter showers or baths with a partially filled tub. Be cautious about excessive use of large soaking tubs.

- Don't let water run unnecessarily while brushing teeth or washing hands, food, dishes, etc.
- Wash dishes and clothes when you have a full load.
- When possible, avoid doing several loads in one day.
- Use water saving devices on faucets and showerheads.
- When replacing old toilets, buy low-flush models.

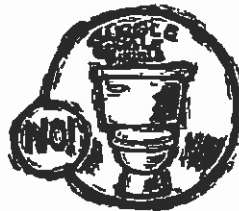

**DON'T** ignore leaky plumbing fixtures; repair them. A leaky toilet can waste up to 2,000 gallons of water in a single day. That's 10-20 times more water than a household's typical daily usage. Leaky plumbing fixtures increase your water bill, waste natural resources, and overload your system.



**DO** keep lint out of your wastewater treatment system by cleaning the lint filters on your washing machine and dryer before every load. Installing a supplemental lint filter on your washing machine would be a good precautionary measure. (This normally takes just a few minutes. Lint and other such materials can make an extreme difference in the frequency and cost of pumping out your primary treatment tank.)



## DO'S AND DON'TS FOR INSIDE THE HOUSE



DO use substitutes for household hazardous waste. Replace the following hazardous products with products that are less environmentally harmful. The hazardous cleaners are listed below, followed by the suggested substitute.

**Ammonia-based cleaners:** Sprinkle baking soda on a damp sponge. For windows, use a solution of 2 tbs. white vinegar to 1 qt. water. Place the mixture into a spray bottle.

**Disinfectants:** Use borax: 1/2 cup in a gallon of water; deodorises also.

**Drain de-cloggers:** Use a plunger or metal snake, or remove and clean trap.

**Scouring cleaners & powders:** Sprinkle baking soda on a damp sponge or add 4 tbs. baking soda to

**Carpet/upholstery cleaners:** Sprinkle dry cornstarch or baking soda on, then vacuum. For tougher stains, blot with white vinegar in soapy water.

**Toilet cleaners:** Sprinkle on baking soda, then scrub with a toilet brush.

**Furniture/floor polishes:** To clean, use oil soap and warm water. Dry with soft cloth. Polish with 1 part lemon juice and 2 parts oil (any kind), or use natural products with lemon oil or beeswax in mineral oil.

**Metal cleaners:** Brass and copper: scrub with a used half of lemon dipped in salt. Stainless steel: use scouring pad and soapy water. Silver: rub gently with toothpaste and soft wet cloth.

**Oven cleaners:** Quickly sprinkle salt on drips, then scrub. Use baking soda and scouring pads on older spills.



**Laundry Detergents:** Choose one with a zero phosphate content or use soap flakes with 1/3 cup of washing soda. (Before switching, wash clothes in pure washing soda to remove residues.)

## DO'S AND DON'TS FOR OUTSIDE THE HOUSE

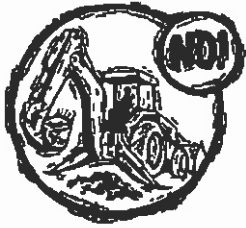

**DON'T** dig without knowing the location of your wastewater treatment system. As much as possible, plan landscaping and permanent outdoor structures before installation. But easily removable items, such as bird baths and picnic tables, are OK to place on top of your system.

**DON'T** ever connect rain gutters or storm drains to the sewer or allow surface water to drain into it. And don't discharge hot tub water into your system. The additional water will increase costs, reduce the capacity of the collection and treatment systems, and flood the drainfield. It can also wash excess solids through the tank.

**DO** keep the tank access lid secure to the riser at all times. If bolts are lost or damaged, call InnoFlow Technologies Ltd immediately for replacement.



**DON'T** drive over your tank or any buried components in your system, unless it's been equipped with a special traffic lid. If the system is subject to possible traffic, put up a barricade or a row of shrubs.

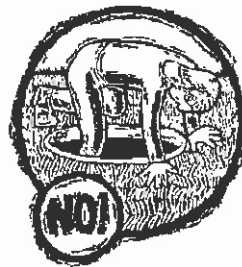

**DON'T** enter your tank. Any work to the tank should be done from the outside. Gases that can be generated in the tank and/or oxygen depletion can be fatal.

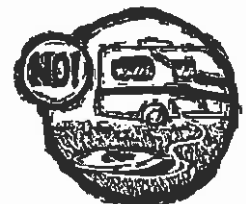

**DON'T** dump RV waste into your wastewater treatment system and tanks. It will increase the frequency of required septage pumping. When dumped directly into the pumping vault, RV waste clogs or fouls equipment, causing undue maintenance and repair costs. (Some RV waste may contain chemicals that are toxic or that may retard the biological digestion occurring within the tank.)



**DO** make arrangements with a reliable service person to provide regular monitoring and maintenance. Place the service person's phone number on or in your control panel!

**DO** keep a file copy of your service provider's sludge and scum monitoring report and pumpout schedule. This information will be beneficial for real estate transactions or regulatory visits.

**DO** keep an "as built" system diagram in a safe place for reference.

## DO'S AND DON'TS AT THE CONTROL PANEL

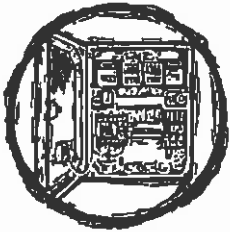

DO locate your electrical control panel where it will be protected from potential vandalism and have unobstructed access.

DO familiarize yourself with the location of your wastewater treatment system and electrical control panel. Refer to the panel's model number (on the back of this booklet) when reporting a malfunction in the system.

DO take immediate action to correct the problem in the event of an alarm condition. Call your system operator or maintenance company immediately whenever an alarm comes on; it sounds like a smoke alarm.



DO remember that the audible alarm can be silenced by pushing the lighted button located directly above the "Push to Silence" label on the front of the electrical control panel. With normal use, the tank has a reserve storage capacity good for 24-48 hours.

DON'T turn off the main circuit breaker to the wastewater pumps when going on vacation. If there is any infiltration or inflow into the system, the pumps will need to handle it.

**Important!  
Caution!**  
*Only a qualified electrician or authorized installer/operator should work on your control panel. Before anyone does any work on either the wiring to the level control floats and pumps in the vault or on the control panel itself, it is imperative to first switch the isolation fuse/breaker and the circuit breakers in the panel to the "Off" positions, then switch "Off" the power to the system at the main breaker!*

# HOMEOWNER'S MANUAL



## IMPORTANT ONSITE SYSTEM FACTS AND CONTACTS

<b>SUPPLIER DETAILS</b>	
Name	Innoflow Technologies Ltd
Address	P O Box 300-572, Albany
Phone	(09) 426-1027, Fax (09) 426-1047
<b>AUTHORISED SERVICE PROVIDER DETAILS</b>	
Name	
Phone	
<b>AUTHORISED INSTALLER DETAILS</b>	
Name	
Phone	
<b>ELECTRICIAN DETAILS</b>	
Name	
Phone	
<b>COUNCIL DETAILS</b>	
Contact Name	
Phone	
<b>PROPERTY DETAILS</b>	
Lot Number	
Address	
Owner Name(s)	
<b>SYSTEM DETAILS</b>	
Start-up Date	
Control Panel Model	VCOM-S2(nz)RO
Tank Capacity	4500 litres

# HOMEOWNER'S MANUAL



## FREQUENTLY ASKED QUESTIONS

- Q. Can I just get *any* tank for my interceptor tank?  
A. NO. It is important that the interceptor tank is watertight and a specific volume. Also the tank needs the specific fittings for the equipment to be installed correctly.
- Q. Will the interceptor tank smell?  
A. NO. When the tank is correctly installed and operating there are no offensive smells.
- Q. What are the running costs for the interceptor tank?  
A. For the average home, the electrical costs are less than \$10 per month.
- Q. Are there certain things to avoid putting down the sink or toilet?  
A. YES. Read the section on Do's and Don'ts inside the house for a list of cleaning products to avoid and some substitutes.
- Q. Can I put anything in the tank directly?  
A. NO. Never put anything in the tank.
- Q. How often should the tank be pumped out and who is responsible for this?  
A. The interceptor tank and filter equipment are engineered to require pump out only every 8-10 years for normal use. Your service provider will monitor this and let you know when this is required.
- Q. Who does the servicing of the interceptor tanks and how often?  
A. Preventative maintenance and inspection should be undertaken by the authorised service provider on an annual basis.
- Q. What do I do if an alarm goes off?  
A. If your phone lines go down in an emergency (severe weather, other unexpected circumstances) and your panel needs to make an alarm call, it will keep trying until, at some point, it will sound a "local alarm." That means, the light on the front of the panel will start flashing and you'll hear an audible alarm sound. **IF YOU HEAR AN AUDIBLE ALARM, CALL YOUR SERVICE PROVIDER IMMEDIATELY.** Then stop the alarm sound by pressing the light button on the front of the panel.
- Q. Is there a problem if there is a power cut?  
A. The tank has over 24 hours emergency storage and so a power outage should have no effect unless it lasts for several days!
- Q. Who should I call if I think there is something wrong with the interceptor tank?  
A. Call your authorised service provider. Their details should be filled in on the "Important System Details and Contacts" form, included in this manual.



# HOMEOWNER'S MANUAL



## INSTRUCTIONS FOR INSTALLERS

The homeowner will have ordered the on-lot equipment and tank from Jacks Point.

IT IS IMPORTANT THAT SUBSTITUTE EQUIPMENT OR TANKS ARE NOT USED. THIS COULD RESULT IN POOR PERFORMANCE AND DAMAGE TO THE EFFLUENT SEWER AND TREATMENT PLANT.

The following instructions provide guidelines for siting and connecting the ProSTEP™ interceptor tank. A commissioning checklist is included. Also included are instructions for installing and testing

## PROSTEP™ INTERCEPTOR TANK INSTALLATION AND CONNECTION

### Guidelines for Siting the Tank

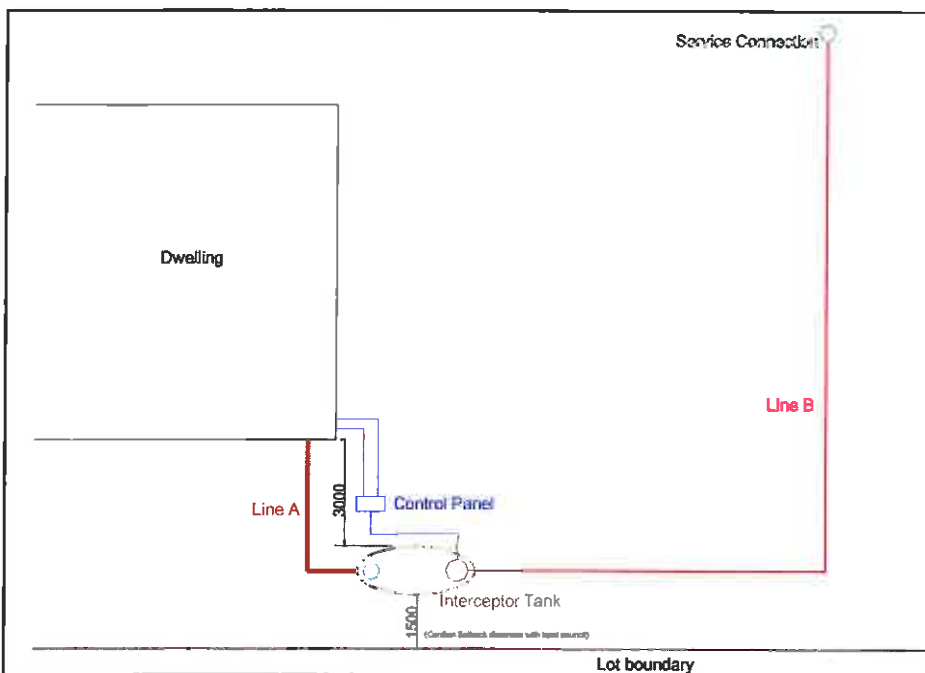

#### Line A:

- Must gravity feed from dwelling to interceptor tank at 1:60
- Responsibility of homeowner
- Length and depth not critical but deeper than 700mm at tank inlet end means special consideration for tank design

#### Interceptor Tank:

- Standard size 4500 litres suitable for up to 4 bedroom home
- Must be installed using standard installation practices

#### Line B:

- Does not have to gravity fall
- Installed in conjunction with - Interceptor tank
- Allowance of up to 25 metres in standard price. Extra pipe can be arranged at \$10 per metre

Figure 4 Tank Siting Guidelines

arranged at \$10 per metre

#### Control Panel & Connections:

- If possible, should be installed in view of tank
- Should not be installed on an exterior wall near a window
- Requires 240V AC
- Requires standard telephone connection
- Requires connection via 7-core cable to floats and pump installed in tank
- All connections to panel are homeowners responsibility
- Once the panel has been fully wired up, contact InnoFlow to arrange commissioning of the system.
- DO NOT CONNECT THE PHONE LINE

#### Service Connection:

- Installed at time of mainline installation
- Typically 1 metre inside property boundary
- Once system is commissioned and running, service connection should be left in open position

# HOMEOWNER'S MANUAL



## House to Interceptor tank Connection

The house to interceptor tank connection is a standard 100mm (110mm DWV) gravity sewer pipe that takes the raw wastewater from the dwelling to the interceptor tank. The supply and installation of this connection is the responsibility of the homeowner and should be undertaken by an experienced Registered Drainlayer.

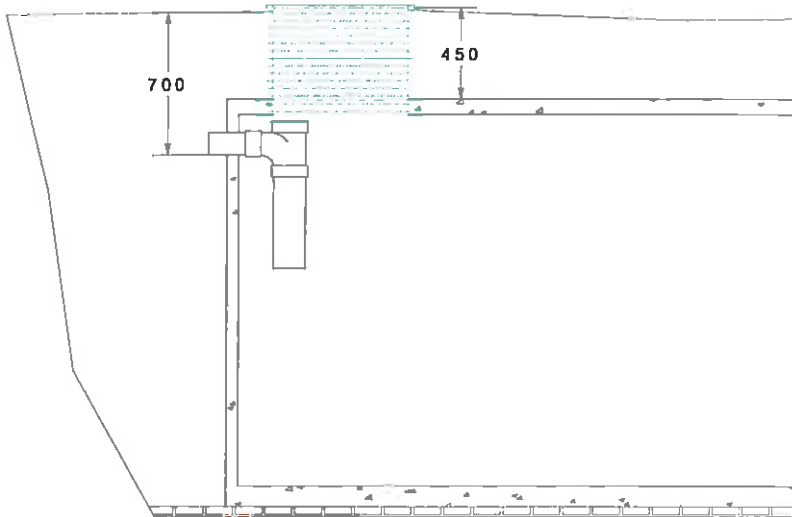

As per The Building Code, this must be laid at a gradient of 1:60 (1 metre fall in every 60 metres), and while its depth is not critical, the standard interceptor tank is based on an inlet invert depth at the tank of 700mm from finished ground.

Care should be made when siting the tank and laying the house to interceptor tank connection as tanks that end up deeper than 700mm at the inlet invert will need special consideration in their design and construction.

Figure 5 Typical depth of bury of tank showing height of inlet invert

Areas of land directly over the interceptor tanks can be landscaped or gardened, however it is important to ensure the access risers are kept clear of plants, sculptures or ornaments that are difficult to move. Small items such as pot plants are fine to be placed over the access risers. (see figures 6 and 7).



Figure 6. Blending the ProSTEP™ interceptor tank into the surroundings

Once the tank has been installed and commissioned, it needs to be filled with water to prevent possible floatation before use. Ensuring there is an adequate water supply on site is the responsibility of the homeowner.



**Figure 7.** A ProSTEP™ installation in a bark garden, note control panel. Brown lids are also available on request

## **Service Lateral**

From the interceptor tank, the screened effluent pumps to the service connection and then *ProSTEP™* Effluent Sewer mainline via a service lateral. This lateral is typically 32mm OD medium density polyethylene and will be supplied in conjunction with the interceptor tank.

The standard pricing for an interceptor tank includes an allowance of up to 25 metres of service lateral pipe. Additional pipe over and above this will be charged at \$10 per metre (supply only).

Because each on-lot system is pumped at *Jacks Point*, no minimum slope is required for this line between the tank and service connection. It can be laid in a 400 mm deep trench.

# HOMEOWNER'S MANUAL



## Service Connection

The final piece of equipment relating to the ProSTEP™ Effluent sewer on each property is the Service Connection, installed in conjunction with the ProSTEP™ Effluent sewer mainline. You may have seen the green fibreglass lid covering the service connection and located close to the property boundary.

This is an isolation valve system that was installed at the same time as the effluent sewer mainline. It is housed within an access riser, typically 1 metre inside the property boundary. This service connection is used to isolate each tank from the main sewer line during testing, commissioning and routine maintenance.

It is important that the service connection be left in the open position once the ProSTEP™ on-lot interceptor tank has been installed, connected and all electrical testing and commissioning completed. This valve should be closed only by a service technician during routine maintenance or during an emergency.

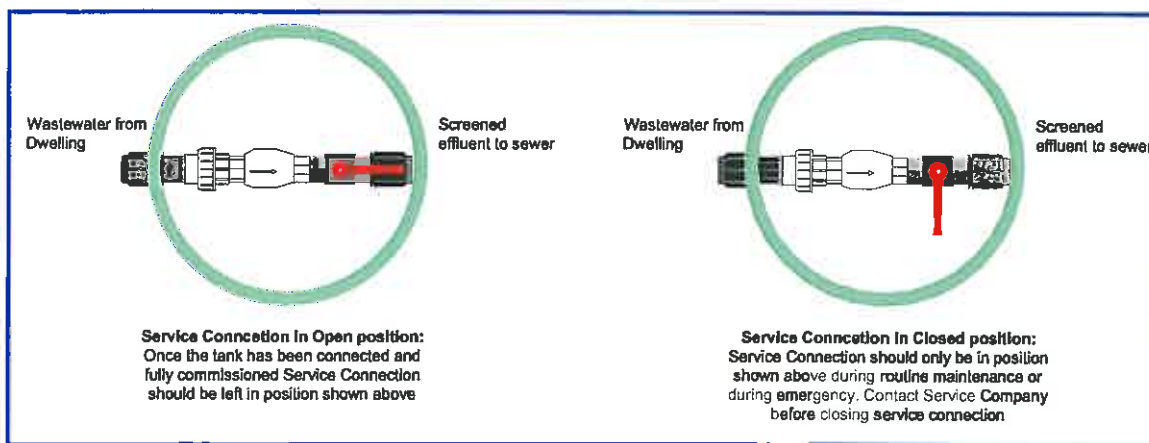

Figure 8. Position of the service connection handle when open (left) and closed (right)

# HOMEOWNER'S MANUAL



## ProSTEP™ On-lot Interceptor Tank Order Form

*Jacks Point*

Please complete the following and return to Innoflow Technologies along with your payment.  
Upon receipt Innoflow Technologies will process your order and return the form to you

<b>Date of Order</b> (Prepayment required prior to dispatch)		<b>Date Required</b> (Allow 8 weeks)		<b>Date Processed</b> (Innoflow Use Only)	
---	--	---	--	--	--

### CONTACT DETAILS

Name	
Phone(s)	
Fax	

### Ordering

Jacks Point Contacted and order placed.

### SITE DETAILS

<b>Lot Number:</b>
<b>Number of Bedrooms*:</b>
<b>Description of Site Access</b> (specify any restrictions) (NOTE: Typically, a 12 tonne digger is used for the installation)
*If your dwelling has more than 4 bedrooms, Innoflow Technologies will be in touch regarding a custom designed Interceptor tank for your home.

### ADDITIONAL EXTRAS

Service	Tick if required	Distance required
Additional Service Lateral over and above 25 metres (\$10/m supply only)		
Electrical Supply and Hookup - Pump and floats to panel only (P.O.A)		



# HOMEOWNER'S MANUAL



## ProSTEP™ On-lot Interceptor Tank Checklist

Jacks Point

### HOMEOWNERS

Upon receipt of homeowners manual:

- Read this homeowners manual
- Apply for building consent, including
  - Building Consent Application form (from Council)
  - System Specification (from InnoFlow Technologies, refer back of manual)
  - Drawing of tank (from InnoFlow Technologies, refer back of manual)

### AT LEAST 8 WEEKS BEFORE TANK IS NEEDED

- Order tank off Jacks Point (using enclosed order form) along with payment

1 week prior to date indicated on returned order form

- Confirm access to site still suitable for 12 tonne digger
- Confirm delivery date with InnoFlow Technologies and if applicable, Installer
- Confirm final position of interceptor tank with installer
- Arrange Electrician for control panel wiring and telephone connection

### DAY OF INSTALLATION

- Ensure site is clear of other workers/contractors/obstructions
- Ensure water supply is established to fill tank

---

### INSTALLER

Post-installation

- Tank filled with water
- Standard sewer line from dwelling installed and connected to tank
- Service connection valve in open position

### ELECTRICIAN

Post-installation

- Electrical wiring from pumps and floats to control panel connected
- Electrical mains hook-up to panel connected
- Power to panel turned on
- Telecom line available at panel with RJ12 Connection jack at end

**Contact InnoFlow Technologies to commission system 094261027**

**(DO NOT PLUG THE PHONE LINE IN TO THE CONTROL PANEL; LEAVE TELEPHONE LINE TERMINATED AT RJ12 CONNECTION JACK. CONTACT INNOFLOW TECHNOLOGIES TO COMMISSION YOUR SYSTEM)**

Once the above checklist has been complete, and InnoFlow Technologies have also supplied you with a commissioning checklist, the system is now ready to use.

# HOMEOWNER'S MANUAL



## PROSTEP™ ON-LOT INTERCEPTOR TANK SPECIFICATION DATA SHEET

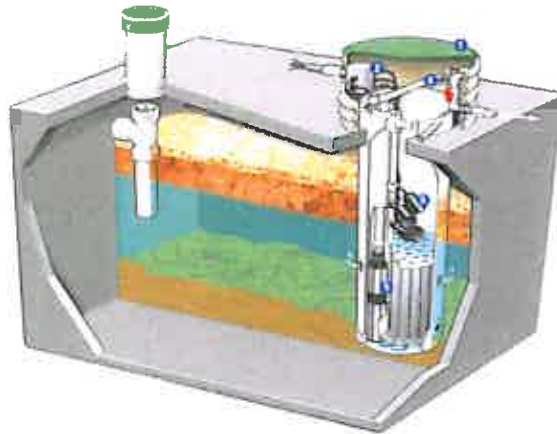

<b>Wastewater Source</b>	Up to 4 bedroom dwelling
<b>Nature of Wastewater</b>	100% domestic. Black and grey water combined
<b>Maximum Daily Flow</b>	1,200 litres
<b>Tank Manufacturer</b>	Buford Tanks
<b>Tank Volume</b>	4500litres operating volume
<b>Detention Time @ Design Flow</b>	~4 days
<b>No of Compartments</b>	1
<b>Construction</b>	Precast Mortar
<b>External Dimensions</b>	3.3m long x 1.6m wide x 1.75m high
<b>Operating Level</b>	1379 –1479mm Internal
<b>Timer Operate Level</b>	1379mm
<b>Alarm Level</b>	1479 mm
<b>Screened Pump Vault Type</b>	1 x Orenco PVU57-24 (300 mm dia x 1450 mm high)
<b>Materials of Construction</b>	Polyethylene Vault with Polypropylene Screen
<b>Biotube Cartridge Height</b>	610 mm
<b>Screen Area</b>	1.89 m <sup>2</sup> each
<b>Pump Model</b>	OSI P100552 High Head Turbine, 0.375 kW, 230V, Single phase
<b>Pump Performance</b>	Max Flow 2.9 m <sup>3</sup> /hr      Max Head 60 m
<b>Pump Discharge Size</b>	25 mm BSP
<b>Access Manhole Type</b>	610 mm Dia PVC Riser with Locking Fibreglass Lid with Rubber Grommet penetrations 450 mm Dia PVC Riser with Locking Fibreglass Lid
<b>Service Lateral Type</b>	RL32 32mm (OD) Medium Density Polyethylene
<b>Service Connection Type</b>	Jack Point own 25mm Service Connection

